



Chainings Limited

Units 1 & 2 Harrow Park, Harrow Road, Hereford, HR4 0EN, United Kingdom
Telephone: + 44 (0) 1432 356318 Fax: +44 (0) 1432 360808
Email: info@chainings.com

TECHNICAL BROCHURE

**CHAININGS FILTER ASSEMBLY FOR USE
ON HYDRAULIC MEDIUM PRESSURE APPLICATIONS**

REF. CHO2010HY



CONTENTS

1. INTRODUCTION
2. SYSTEM FEATURES
3. PRINCIPLE OF OPERATION
4. INSTALLATION
5. SPECIFICATIONS
6. FILTER ELEMENT CHANGE PROCEDURE

1. INTRODUCTION

It has been well documented, that the introduction of fine filtration on hydraulic or lube oil systems has proved to be advantageous in respect of reduced component wear and extended oil life.

The ingredients of particulate or aqueous based contamination in any system, can have serious effects on the integrity of the oil resulting in component fatigue, erosion, corrosion and depletion of oil additive and/or lubricating properties. This in turn, will lead to more than frequent oil changes and maintenance o any system which, in itself, is costly.

Most oil based systems should have filtration packages as specified from design stage, however, it is evident that the need for extra fine filtration can become necessary for even the presence of the smallest particulate contamination below the O.E.M. filtration levels, may influence component wear and oil degradation to beyond the expectations of the end-user.

To compliment the need to maintain a high level of oil system cleanliness, the Chainings Filter product may be installed.

Housed in a simple, yet rugged design, the unique filter element media provides the ability to reduce and maintain contamination levels, be it particulate or water based, to a high degree of oil system cleanliness.

To compliment the Chainings Filter product, a strict quality system is installed to;

“Ensure that whoever the customer is and whatever their requirements, an assured product is supplied to expectations in terms of value, efficiency and time”

Note: The Chainings Filter product is suitable for use on a wide range of mineral oils and a certain amount of synthetic fluids may also be filtered after consultation with the manufacturer.

However, there are types of fluids that cannot be cleaned using the Chainings filter which include the following:

- Oils or fluid with properties that may corrode the Chainings product seal and any associate pipework. e.g. Phosphate Esters.
- Oils or fluids with sufficient water based properties that may be reduced as a result of the Chainings filter element retention. e.g. Fire Resistant Fluids.

It is advisable to contact the manufacturer before cleaning oils or fluids where the characteristics are not known.

2. PRODUCT FEATURES

- 2.1 Filter Housing A suitably sized Pressure Vessel consisting of a three major part assembly. With emphasis on the resistance to corrosion, this simple, yet rugged, design incorporates BSP “tapped” ports for connection of the filter to the oil system that is to be cleaned. Facilities exist for the decaying of pressure and the easy assistance of filter lid removal when changing the filter element. Mounting facilities are also featured to install the filter assembly into the optimum position.
- 2.2 Check Valve Manifold Fitted to the underside of the Chainings Filter Assembly. This manifold features suitably sized drillings and relief valves to enable the Chainings filter to be connected to hydraulic circuits with system pressures ranging from 10 to 50Bar maximum. For added safety, there are two Outlet ports for connection to the hydraulic system reservoir and are sized at 3/8”BSP. The Inlet port is sized at 1/4”BSP and a “Minimes” Test Adaptor is also featured to enable monitoring of filter element health.
- 2.3 Filter Element Based on the “Scroll” type design, the filter element consists of a unique, and patented, Alpha-Cellulose material which is wound onto a robust Centre core using a constant applied tension and sealed in a rigid Polypropylene shroud and end cap. When fully assembled into the Filter housing, this assembly, along with the Base plate spigot “O” Ring seal which locates onto the centre core, is so designed to ensure that all fluid flowing through the filter, passes exclusively through the media.

3. PRINCIPLE OF OPERATION

The concept of the Chainings filter product, is to remove contamination that may be present in the oil of the system that is to be cleaned. This is achieved by connecting the Filter Assembly to the system under the constraints listed in Sections 4 and 5 of this manual. Oil within the system, will travel through the centre of the Chainings filter assembly and, subsequently, pass through the filter media before returning to the system via the Outlet port. The pore structure and absorbent characteristic that the filter media possesses, helps to trap particulate matter and water contaminants as the oil flows through, without “media migration” and without affecting the oil’s additive package. Seals are incorporated into the design that help to prevent any oil bypassing the filter media.

To achieve the desired level of cleanliness, it will be necessary to pass the oil through the filter media, several times. Experience has shown, that to effectively remove contamination to a high level of cleanliness, ten passes of oil through the filter media is required.

This is of course, dependent on the level of contamination to start with, but does act as a general guide.

4. INSTALLATION

This section covers the installation of the Chainings filter with Check Valve manifold on medium system pressure circuits of a hydraulic system. (Real Time filtration) There are two other types of Chainings filter application onto hydraulic systems dependent on the selection, namely:

1. Chainings filter for use on High Pressure applications
2. Chainings Filtration or Fluid Conditioning rigs

The installation guidelines for these two products are covered by their own respective Technical Publications.

i) Location of the Chainings Filter Assembly:

Location of the Chainings Filter Assembly, is determined by the following;

- A position which is not likely to impede any mechanical movements of the system being fitted.
- The clearance required to remove the filter assembly lid and change the element.
Note: The assembly is normally mounted in an upright position to minimise oil spillage when replacing the filter element, although this is not essential for the efficient operation of the filter.
- The facility to fasten the filter mounting bracket onto a strong and secure member of the system framework.

Notes: Do not locate the filter assembly in any area that is subject to frequential vibration.

- The ability to easily view any visual filter blockage indicator if fitted.
- The ability to operate a supply isolating valve if fitted.
- Consideration given to the routing and connection of the supply and return hosework to and from the Chainings filter assembly respectively.

ii) Connection

The filter is installed as a Bypass principle and may be connected onto system hydraulic pressure circuits not exceeding 40Bar.

There are two return paths, both for connection of the Filter Outlet and Manifold Relief Valve drain to the system reservoir.

A “Minimess” Test point is featured on the Filter Check valve manifold for monitoring filter pressure and performance values.

Notes:

Reccomended to connect Inlet of filter downstream of any “In-line” filtration located in the pressure circuit

Maximum return pressure not to exceed 2Bar

IMPORTANT NOTICE

Ensure that this path to Return is not, in anyway, restricted or liable to restrictions during the course of normal installation system operation.

iii) Filter change intervals:

It is recommended that on “normal” hydraulic system where **no** extreme contamination levels exist, the filter element should be replaced every 1000 Hours or unless oil analysis permits extended life.

It would be up to the discretion of the end-user and their judgement if the element should be replaced on more frequent intervals should undue amounts of contamination be present e.g. Excessive aqueous based contamination.

5. SPECIFICATIONS.

Filter Assembly Part No:	CHO2010HY
Filter Element Part No:	OCH2010
Weight (Filter Housing):	19Kgs
Weight (Filter Element):	1.2Kgs
Oil Displacement Volume:	2.5Litres
Filter Efficiency:	3micron @ 99.87%
	5micron @ 99.82%
Water Retention:	400ml
Maximum Applied System Pressure:	40 Bar
Minimum Applied System Pressure:	10 Bar
Maximum Return Pressure (OUT and TANK)	2 Bar
Nominal Flow Rate:	3Lpm
Maximum Oil Temperature:	80Deg C
Inlet Port Size:	1/4" BSP
Outlet Port Size (OUT):	3/8" BSP
Outlet Port Size (TANK):	3/8" BSP
Material spec.	Filter Housing: Cold Drawn Seamless STS2 Din2391
	Base and Lid: EN3
	Manifold: EN1
	All seals: Viton 75
	Fastenings: Stainless Steel Austenitic
Protective Treatment (Manifold, Housing, Lid, Base)	Electrophoretic Paint
	500-750Hrs Salt spray resistance
Clamping Nut Torque (M8 Fasteners):	20Nm
Recommended Attachment Bolt Size:	M10 (4 Positions)④

NOTES: This product is fully tested to specification before it leaves the manufacturers premises. Should any queries or problems arise, then the manufacturer should be contacted immediately. Adjustments made to the product without prior knowledge of the manufacturer may invalidate any warranty claims.

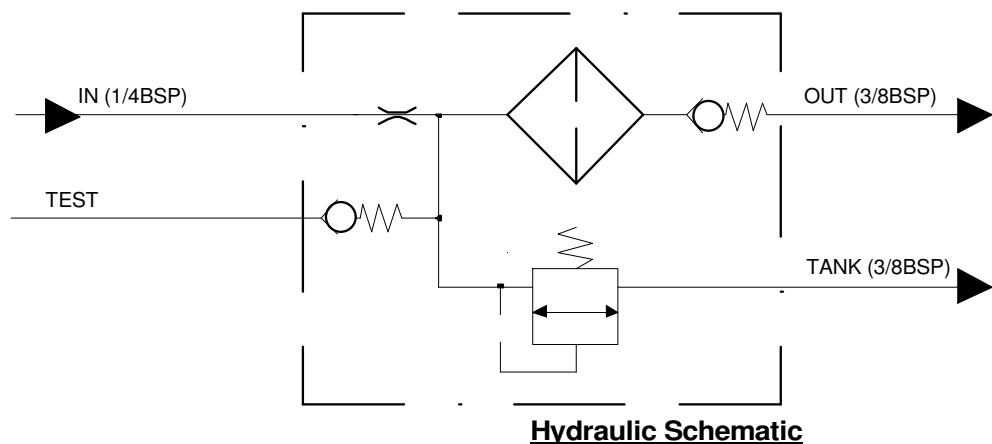

5. SPECIFICATIONS Cont.

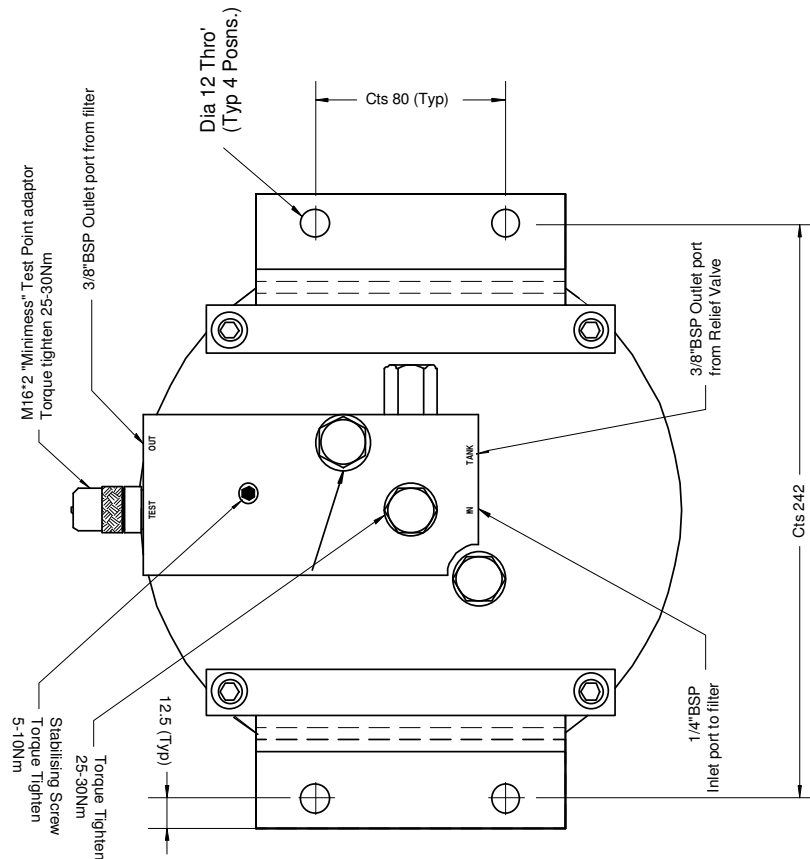
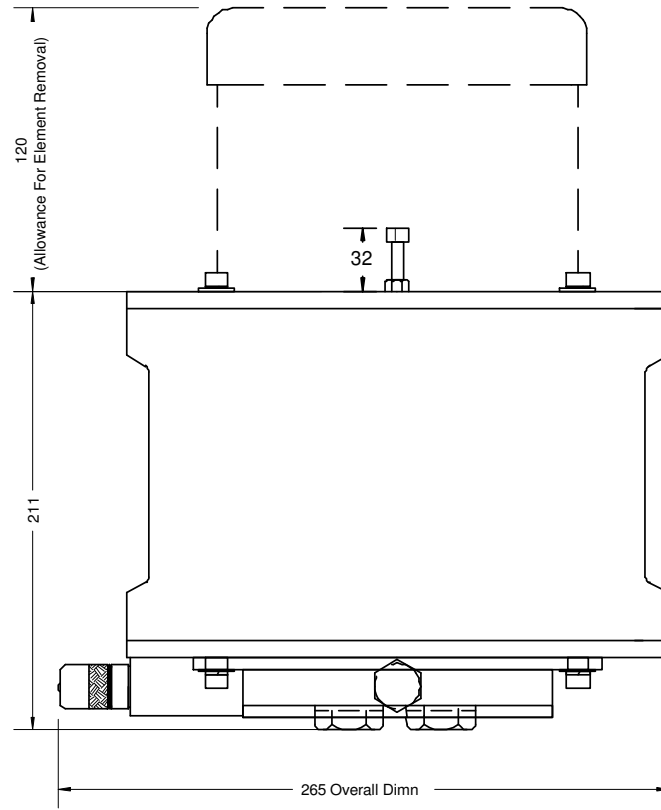

6. FILTER ELEMENT CHANGE PROCEDURE

Removal of used element:

1. If fitted turn the “Inlet” Isolating valve to the Closed position.
2. Gradually loosen the Bleed Screw fitted on top of the Filter Lid, to decay any residual pressure.
WARNING: Care should be taken to avoid the risk of oil contacting the operator in the event of undue pressure being released.
3. Loosen and remove the M8 clamping screws, spring washers and plain washers securing the lid to the Filter Housing.
4. Unlock the nuts fitted to the underside of the two M8 bolts located on the Filter Lid and screw the bolts downwards to assist with the removal of the Lid.
5. Once the Filter Lid has been removed, pull the filter element upwards and away from the Filter Housing.
6. Depose the filter element in accordance with any legislative procedures that may be applicable.

Installation of new element:

1. Ensure that the Filter Housing is clean and free of contaminates and that the “Inlet” and “Outlet” ports are not blocked.
2. Ensure that the “O” Ring on the Centre Tube is correctly positioned and not damaged.
3. Install the replacement Filter Element and ensure that it is seated firmly at the bottom of the Filter Assembly.
4. Ensure that the “O” Ring on the Filter Lid is correctly positioned and not damaged.
5. Apply a film of clean oil around the “O” Ring on the Filter Lid and ensure that the ends of the two bolts used for extraction purposes, are not protruding through the bottom of the Filter Lid.
6. Line the holes in the Filter Lid up with the tappings in the Filter Housing and press down to locate the Lid.
7. Replace the Clamping screws, Spring washers and Plain washers and Torque tighten each screw in a diagonal fashion, to 20Nm.
8. Hand tighten the two bolts on the Filter Lid and lock to the lid with the nuts fitted to the underside of each bolt. **Note: The filter element has been designed to compress as the lid is being tightened down.**
9. Re-tighten the Bleed Screw fitted to the Filter Lid.
10. If fitted, turn the “Inlet” to the “Open” position.

WARNING ALWAYS USE GENUINE CHAININGS FILTER ELEMENTS